



Customer:

Customer Model Number:

Product Part Number: PXX9025AWPL6A

1. Input Requirement

Input Voltage & Frequency

	Minimum	Nominal	Maximum
Input Voltage	90Vac	100-240Vac	264Vac
Input Frequency	47Hz	50/60Hz	63Hz

Input Current: 500mA Max. at 100Vac – 240Vac

Inrush Current

The inrush current will not exceed 50A at 100-240Vac input and Max load for a cold start at 25°C.

Efficiency

The No-Load power consumption shall be less than 0.1W at input 115/230 Vac.

The average active mode efficiency shall be higher than 86.21% at input 115/230 Vac.

International Efficiency Level VI

2. Output Requirement

	Minimum Value	Typical	Maximum Value	Test Condition at 25 °C
Output Voltage	8.55Vdc	9.0Vdc	9.45Vdc	0 ~2.5A Loading
Output Load	0A	-	2.5A	
Ripple and Noise	-	-	200mVp-p	20MHz Bandwidth 10uF Elec. Cap.0.1uF Cer. Cap.
Output Overshoot	-	-	10%	MAX. Load & 100- 240Vac

Turn On Delay

During turn on and turn off, no output voltage shall exceed its nominal voltage by more than 10% and no output shall change its polarity with respect to its return line. All outputs shall reach their steady state values within 3 seconds of turn on.

Hold Up Time

DWG Control Number:

Revision:

Date: 4/14/2016



10 ms minimum at 115Vac/60Hz input at maximum load, and 20 ms minimum at 230Vac/50Hz input at maximum load.

Output Transient Response

The power supply shall maintain output transient response time within 1500mV with a loading current change from 20% to 80% of maximum current and 0.5A/μs rise up /drop down test at end of output terminal.

3. Protection

Over Voltage Protection

Over voltage protection shall be included in the adaptor circuit. A single component failure must not cause an over voltage.

Over Current Protection

The adaptor must have a current limiting function on the output voltage. in overload mode, the output must drop to a low voltage. The OCP 4.0A max.

Short Circuit Protection

The adaptor must withstand a continuous short circuit on the output without damage.

4. Environmental Requirement

Operating Temperature: 0°C ~ 40°C

Storage Temperature: -10°C ~ 60°C

Operating Humidity: 10% ~ 90%

Storage Humidity: 5% ~ 95%

Attitude: Sea level to 2,000 m.

Cooling Method: Natural convection cooling.

5. Reliability and Quality Control

MTBF

When the power supply is operating within the limits of this specification the MTBF shall be at least 50000 hours at 25°C (MIL-HDBK-217F).

Burn-In

The power supply shall withstand a minimum of 4 hours Burn-In test under full load at 35°C ~40°C room temperature, after test, product shall operate normally.

Component De-rating

DWG Control Number:

Revision:

Date: 4/14/2016



Semiconductor junction temperatures shall not exceed the manufacturer's maximum thermal rating.

6. Mechanical Requirement

Case Dimension: See Drawing

Cable Type: AWG18#/2C UL2468 BLACK

Cable Length: 1830 +50/-0

Output Connector: 5.5mm x 2.5mm x 9.5mm

7. Safety

Safety Standard

The power supply shall be certified under the following international regulatory standards.

Item	Country	Certified	Standard	Present
UL	USA	APPROVED	UL60950-1 2 nd /UL60065	✓
CUL	Canada	APPROVED	CSA C22.2 NO.60950-1/UL60065	✓
FCC	USA	APPROVED	PART 15 CLASS B	✓
VDE/GS	Europe	APPROVED	EN 60950-1 2 nd /EN60065	✓
CE	Europe	APPROVED	EN 60950-1 2 nd /EN60065	✓
BS/UK	Britain		BS EN 60950-1 2 nd /EN60065	
SAA	Australia	APPROVED	AS/NZS 60950-1/NZS60065	✓
CCC	China		GB4943	
Ko	Korea		K60950	
PSE	Japan	APPROVED	J60950 (H20)/J60065	✓
Others				

Insulation Resistance

Input to output: 10 MΩ min. at 500 VDC.

Dielectric Strength (Hi-Pot)

Primary to Secondary DC4242V or AC3000V 10mA 1 minute for type test, 3 seconds for product.

Leakage Current

The leakage current shall be less than 5mA for Class II when the power supply is operated maximum input voltage and maximum frequency.

8. EMC Standards

DWG Control Number:

Revision:

Date: 4/14/2016



The power supply shall meet the radiated and conducted emission requirements for EN55022 CLASS B, FCC PART 15 CLASS B.

EMS Standards(EN55024)

The power supply shall meet the following EMS standards.

- IEC61000-4-2 Electrostatic Discharge (ESD)
Static – discharge test by contact or air should be conducted with Static – discharge teeter, energy storage capacitance of 150pF, and discharge resistance of 330Ω. 8KV air discharge, 4KV contact discharge, Performance Criterion B.
- IEC61000-4-3 Radiated Electromagnetic Fields(RS)
Radio- frequency Electromagnetic Field Susceptibility Test, RS, 80-1000MHz, 3V/m, 80%AM(1KHz), Performance Criterion A.
- IEC61000-4-4 Electrical Fast Transient / Burst (EFT)
Power Line to Line: 1KV
Performance Criterion B.
- IEC61000-4-5 Lightning Surge Attachment
Lightning Surge voltage of differential and common modes shall be applied across AC input lines and across input and frame ground.
Power Line to Line (Common Mode): 1KV
- IEC61000-4-6 Conducted Radio Frequency Disturbances (CS)
Conducted Radio Frequency Disturbances Test, CS, 0.15-80 MHz, 3V/m, 80%AM, 1KHz, Performance Criterion A.
- IEC61000-4-11 Voltage Dips/Short Interruption/Variations
Voltage Dips, 30% reduction- 10ms, Performance Criterion B, 60% Reduction – 100ms, Performance Criterion C, Voltage Interruptions>95% Reduction- 5000ms, Performance Criterion C.

9. Other Requirement

Hazardous Substances

The components and used materials shall be in compliance with EU Directive 2011/65/EU "RoHS 2"

Energy Efficiency

The power supply shall meet the following EMS standards.

- The No-Load power consumption shall be less than 0.1W at input 115/230 Vac.

DWG Control Number:

Revision:

Date: 4/14/2016



GOLDEN PACIFIC ELECTRONICS, INC.
16800 E. Gale Ave, City of Industry, CA 91745 U.S.A
Phone#: 714-993-6970; 626-217-1049
Fax#: 626-968-6897
Website: www.gpelectronics.com
Email: sales@gpelectronics.com

- The average active mode efficiency shall be higher than 86.21% at input 115/230 Vac.
- International Efficiency Level VI
- This power supply is therefore in compliance with the requirements of Energy Star requirements for external power supplies(EPS Version 2.0)

DWG Control Number:
Revision:
Date: 4/14/2016



10. DC Cord

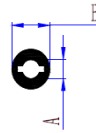
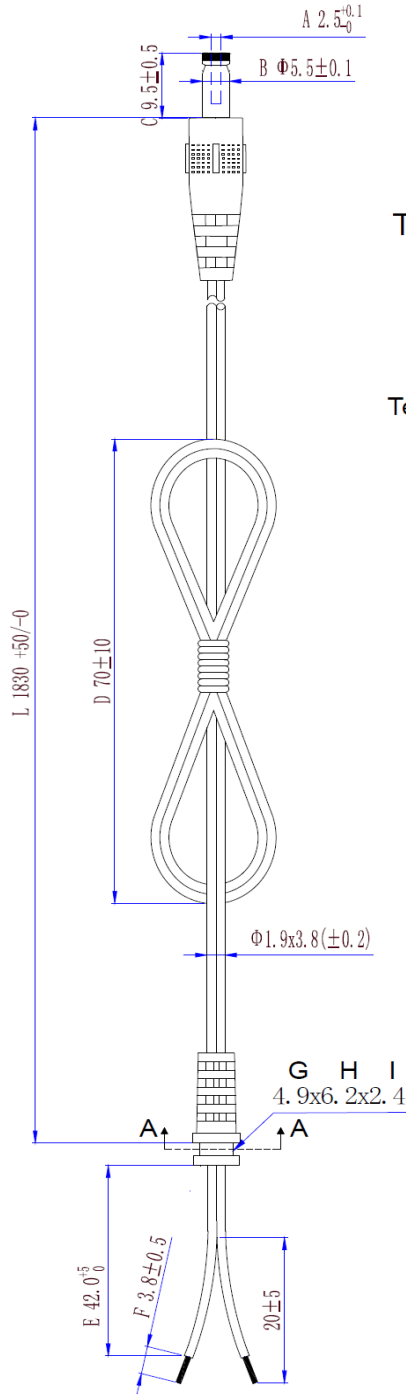

TUNING FORK WITH GROOVE

Technical requirements:

1. Unit: mm
2. Unremarked Tolerance: ±0.3;
3. 18AWGx2C(0.16x41), UL2468; one is black , the other is with white minus sign
4. Mode of connection: wire with white minus sign connect to inner tip
5. Plug swaying test: load 200g weight, distance of hanging point and fulcrum: 30cm, angle: 60° 40 times/minute, min 2000 times
6. S/R swaying test: load 20LB(9072g), continuous 1minute and distance of hanging point and fulcrum is 30cm, displacement no more than 5mm
7. ROHS 2.0

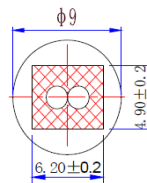

SECTION A-A

Total length(L): 1830 +50/0 (IQC checks)



11. Drawing

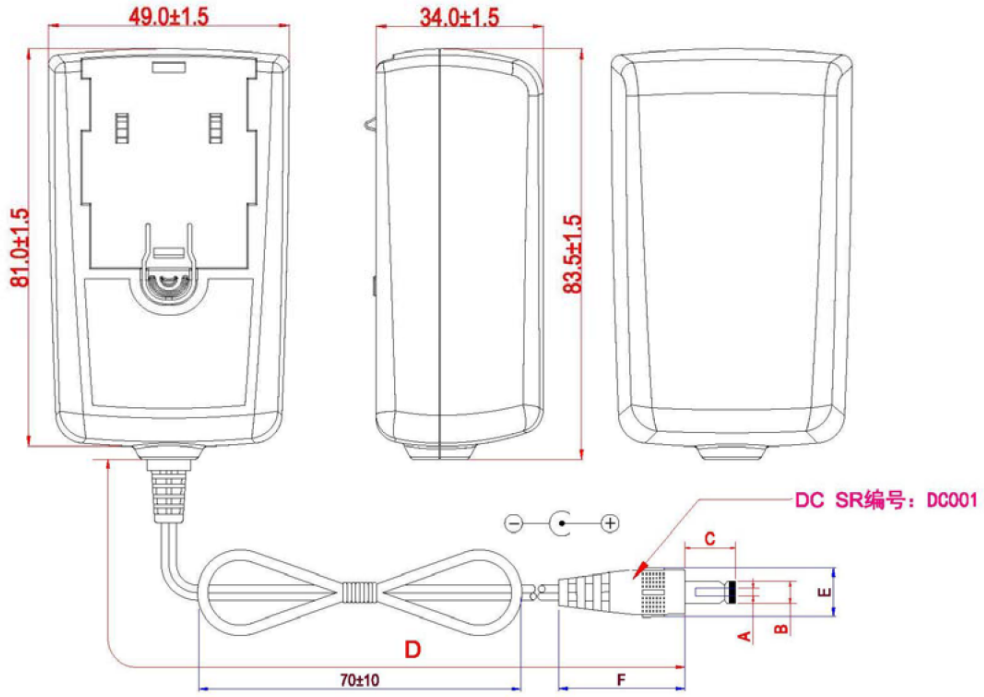

SWITCHOVER PLUG	
<p>UL PLUG</p>	

Unit : mm

	ΦA	ΦB	C	D	ΦE	F
DIMENSION	2.5	5.5	9.5	1830	8.8	26.6
TOLERANCE	+0.1/-0	±0.1	±0.5	+50/-0	+0.2/-0.2	±0.5
REMARK	AWG18#/2C UL2468 BLACK					



12.Nameplate

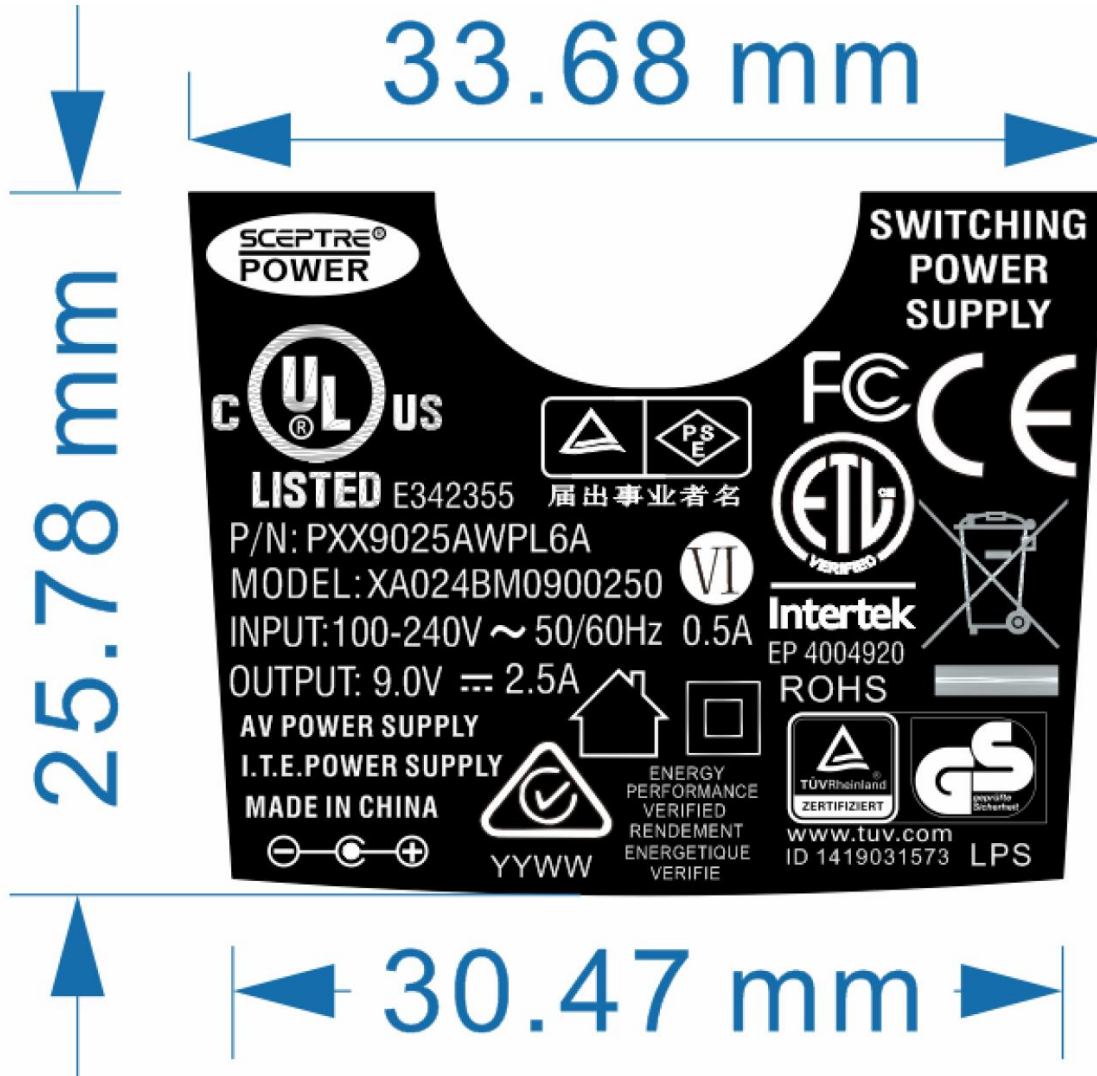

Unit: mm
 Tolerance: +0/-0.2
 Background Color : BLACK
 Word Color: White